



**Parts List  
2" and 3" TPL-9  
Turbo-Meters**

---

**Parts List  
2" and 3" TPL-9  
Turbo-Meters**

## TPL-9 Turbo-Meters, 2" and 3"

### General Assembly, 2" and 3" TPL-9 Turbo-Meter

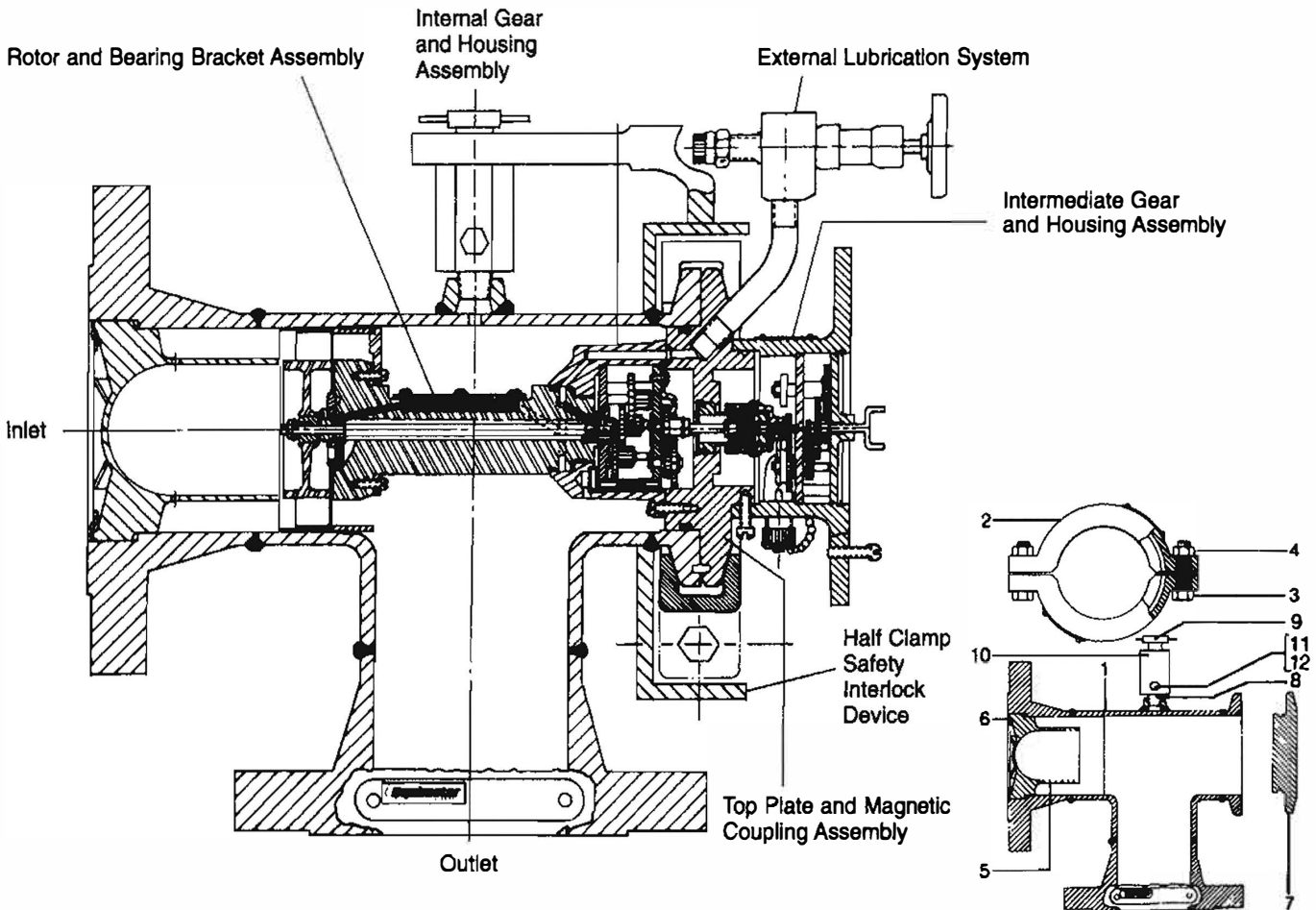

### Body Parts

ILLUSTRATION NUMBER	QUANTITY REQUIRED	DESCRIPTION	2" TPL-9 PART NUMBER	3" TPL-9 PART NUMBER
**1	1	Body Assembly, ANSI 150 (275#)	006-16-600-01	006-20-600-00
**1	1	Body Assembly, ANSI 300 (720#)	006-16-600-51	006-20-600-50
**1	1	Body Assembly, ANSI 600 (1440#)	006-16-600-82	006-20-600-80
2	2	Half Clamp, Forged Steel	006-20-341-00	006-20-341-00
3	2	Bolt, A193GRBTM	950202	950202
4	2	Hex Nut, A194GR7	950201	950201
5	1	Nose Cone, ANSI 150 (275#)	006-16-005-04	006-20-005-02
5	1	Nose Cone, ANSI 300 (720#)	006-16-005-53	006-20-005-51
5	1	Nose Cone, ANSI 600 (1440#)	006-16-005-83	006-20-005-31
6	3	Machine Screw, #8-32 x 3/8", Truss Head, S.S.	950426	950426
7	1	Blank Top Plate (Optional)	006-20-180-00	006-20-180-00
8	AR	Loctite	1191465	1191465
9	1	Relief Valve Stem	006-20-144-01	006-20-144-01
10	1	Relief Valve	006-20-142-00	006-20-142-00
11	1	1/8" Male to 1/4" Female	950553	950553
12	1	1/4"-18 NPT Hex Head Pipe Plug	906055	906055

\*\*Includes serialized badging items - 2 through 12, and O-Ring 950195.

## TPL-9 Turbo-Meters, 2" and 3" Complete Internal Mechanism Assembly

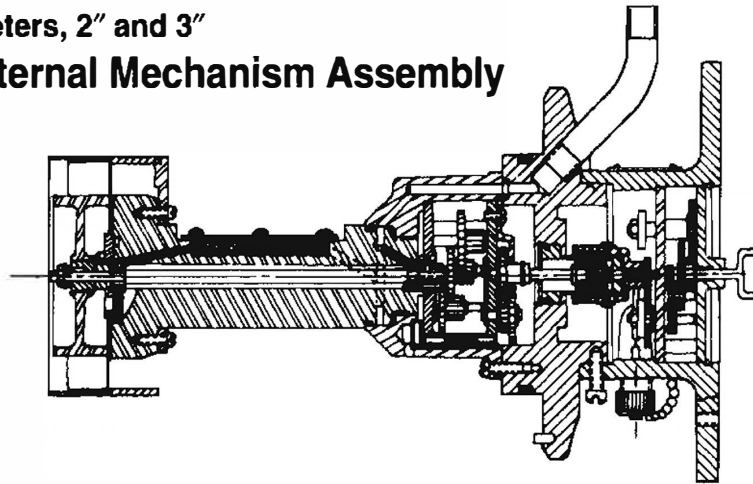

PART DESCRIPTION	METER OUTPUT PER REVOLUTION	PART NUMBER
Assembly With Plug-In Type Pulse Output Connector	100 ACF	006-20-502-17
Assembly With Conduit Type Pulse Output Connector	100 ACF	006-20-502-18
Assembly With No Type Pulse Output Connector	100 ACF	006-20-502-10
Assembly With Plug-In Type Pulse Output Connector	10 ACF	006-16-502-08
Assembly With Conduit Type Pulse Output Connector	10 ACF	006-16-502-09
Assembly With No Type Pulse Output Connector	10 ACF	006-16-502-10
Assembly With Plug-In Type Pulse Output Connector	1.0M <sup>3</sup>	006-20-502-11
Assembly With Conduit Type Pulse Output Connector	1.0M <sup>3</sup>	006-20-502-12
Assembly With No Type Pulse Output Connector	1.0M <sup>3</sup>	006-20-502-13
Assembly With Plug-In Type Pulse Output Connector	0.1M <sup>3</sup>	006-16-502-11
Assembly With Conduit Type Pulse Output Connector	0.1M <sup>3</sup>	006-16-502-12
Assembly With No Type Pulse Output Connector	0.1M <sup>3</sup>	006-16-502-13

**NOTE:** The same Internal Mechanism Assembly is used in all 2" or 3" TPL-9 Turbo-Meters regardless of the meter pressure rating. Complete Internal Mechanism (#502) Assemblies are shipped with individual calibration curves. A spare complete Internal Mechanism (#502) Assembly is recommended for all installations having ten or more TPL-9 Turbo-Meters in service.

## Index Plate Assembly Components

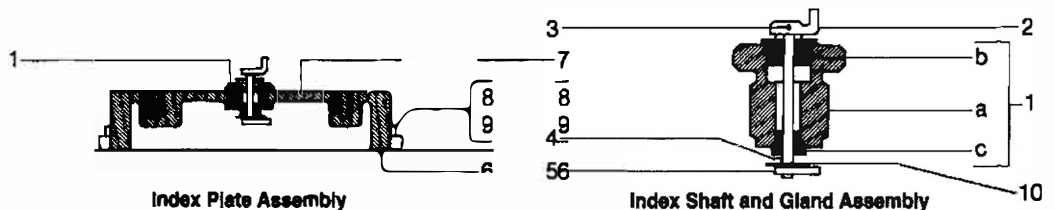

ILLUSTRATION NUMBER	QUANTITY REQUIRED	PART DESCRIPTION	PART NUMBER
1	1	Index Shaft Gland Assembly (Includes Illustration Numbers 1a-c)	006-20-323-00
1a	1	Gland	006-24-023-00
1b	1	Bushing (Top)	006-24-052-01
1c	1	Bushing (Bottom)	001-60-052-62
2	1	Top Index Shaft Dog	006-24-061-04
*3	1	Shear Pin, Top Index Shaft Dog	006-24-056-00
4	1	Index Shaft	006-20-054-00
5	1	Bottom Index Shaft Dog	006-24-071-00
*6	1	Gasket, Index Plate to Top Plate	006-24-160-03
7	1	Index Plate	006-24-004-21
		Complete Index Plate Assembly (Includes Illustration Numbers 1-5, 7 and 10 Above)	006-20-504-02
8	3	Cap Screw, Index Plate to Top Plate, 5/16"-18 x 3/4" Hexagon Head Steel	910028
9	1	Seal Cap Screw, Index Plate to Top Plate, 5/16"-18 x 3/4" Hexagon head Steel	002-65-057-02
10	1	Retaining Ring	950578

\*Indicates minimum recommended spare parts.

## TPL-9 Turbo-Meters, 2" and 3" Rotor Bearing Bracket Assembly

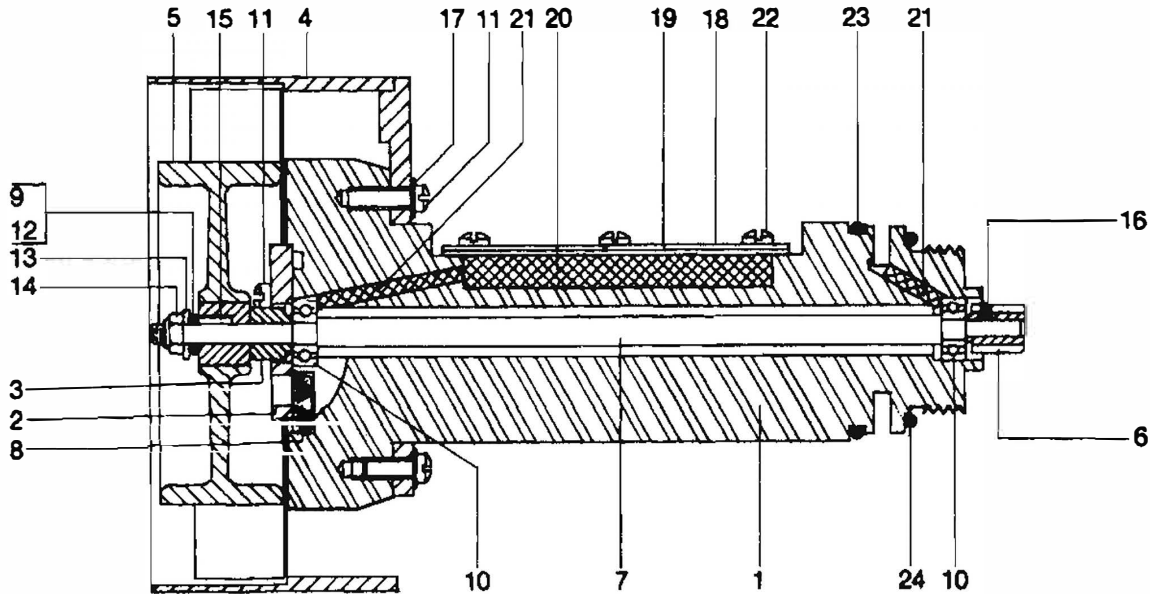

ILLUSTRATION NUMBER	QUANTITY REQUIRED	PART DESCRIPTION	PART NUMBER
1	1	Bearing Housing	006-20-009-02
2	1	Bearing Retainer Plate	006-20-117-01
3	1	Rotor Spacer	006-20-082-01
4	1	Rotor Shell	006-20-110-02
*5	1	Rotor Assembly	006-20-350-00
6	1	Twelve Tooth Gear	006-20-100-12
7	1	Rotor Shaft	006-20-024-00
*8	2	Filter	006-16-083-21
*9	1	O-Ring 7/32" O.D. 3/32" I.D. 1/16" TK. Parker #2-5	904379
*10	2	Bearing	950258
11	6	#4-40 x 5/16" Long Fillister Head Stainless Steel Machine Screw	907195
*12	1	O-Ring, Viton, Parker #2-5	906742
13	1	Washer, 5/16" x 1/8" x 1/32" Stainless Steel	904048
14	1	#5-40 NC ESNA22NTM-50 Hex Nut	904168
15	1	Rotor Locking Pin	006-22-020-00
16	2	#3-48 x 1/8" Long Nylock Socket Set Screw	950217
17	4	#4 Ext. Tooth Lock Washer	950078
18	1	Cover	006-21-053-00
19	1	Gasket	006-21-160-00
20	-	Felt Packing	1190841
21	-	Felt Wick	1191402
22	6	#3-56 x 3/16" Binding Head Stainless Steel Machine Screw	950433
*23	1	O-Ring, #523 EU or Equivalent, 2-024	904826
*23	1	O-Ring, Viton, 2-024	902699
*24	1	O-Ring, #523 EU or Equivalent, 2-022	950251
*24	1	O-Ring, Viton, 2-022	950295
*24	1	Complete Assembly with Calibration Curve and Change Gears: With #523 EU or Equivalent O-Rings With Viton O-Rings	006-20-302-24000 006-20-302-25000

\*Recommended Spare Parts

**NOTE:** The same Rotor Bearing Bracket Assembly is used in 2" or 3" TPL-9 Turbo-Meters regardless of the pressure rating. These complete #302 Assemblies are shipped with individual calibration curves and change gears. A spare #302 Assembly is recommended for all installations having ten or more TPL-9 Turbo-Meters in service.

## TPL-9 Turbo-Meters, 2" and 3" Intermediate Gear and Housing Assembly

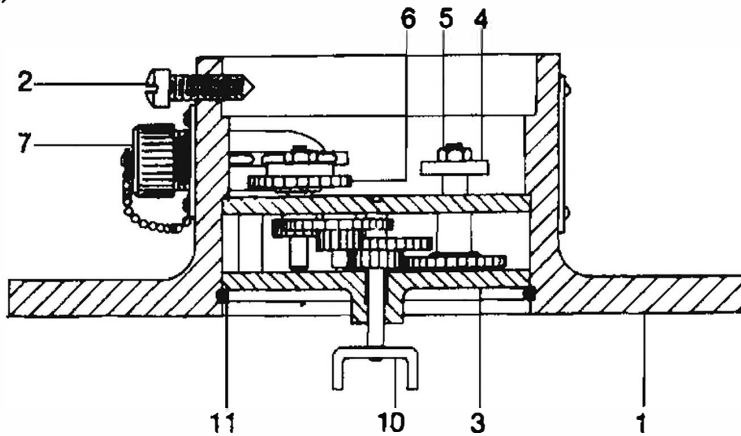

ILLUSTRATION NUMBER	QUANTITY REQUIRED	PART DESCRIPTION	PART NUMBER
1	1	Intermediate Gear Housing (Includes Pin)	006-20-207-02
2	4	#8-32 x 1/2" Lg. Cone Pt. Fillister Head Stainless Steel Machine Screw	006-20-150-00
3	1	Intermediate Gear Assembly (Includes Pulser Magnets and Output Dog) Standard (100 CF/Rev.) or (1.0M <sup>3</sup> /Rev.)	006-20-512-01
3	1	Intermediate Gear Assembly (Includes Pulser Magnets and Output Dog) Special for 10 ACF or 0.1M <sup>3</sup> Per Revolution	006-20-512-02
4	2	Pulser Magnet	006-20-124-00
5	2	Pulser Magnet Nut, #4-40 Hexagon Stainless Steel	907639
6	1	36T Input Gear	006-20-436-00
7	1	Magnet and Gear Housing Assembly (Plug-In) (Shown)	006-20-307-04
7	1	Magnet and Gear Housing Assembly (Conduit Type) (Not Shown)	006-20-307-05
7	1	Magnet and Gear Housing Assembly (No Switch Type) (Not Shown)	006-20-307-03
10	1	Output Dog, Right-Hand Thread	006-24-061-00
11	1	Retaining Ring	006-20-128-00
8	1	Cover Plate (Not Shown)	006-20-031-00
9	4	#4-40 x 1/4" Lg. Rd. Hd. SS. MS. (Not Shown)	903025

## External Lubrication System

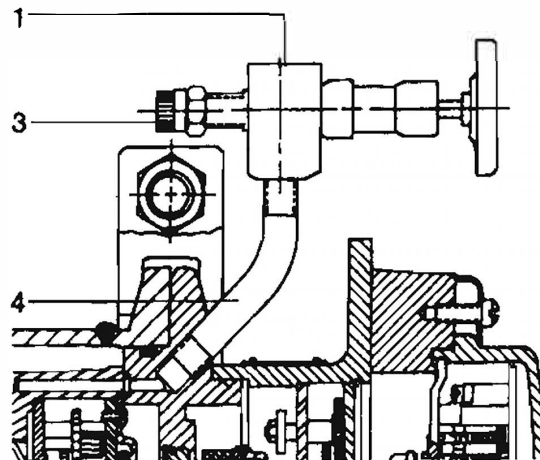

ILLUSTRATION NUMBER	QUANTITY REQUIRED	PART DESCRIPTION	PART NUMBER
1	1	Valve, 1/8" Carbon Steel	950698
3	1	Lubricant Fitting, (Alemite #1650)	006-24-145-00
4	1	Oil Tubing, Schedule 80 External Assembly Includes Illustration Numbers 1 thru 4	006-20-135-01 006-20-300-01

## TPL-9 Turbo-Meters, 2" and 3" Internal Gear Train and Housing Assembly

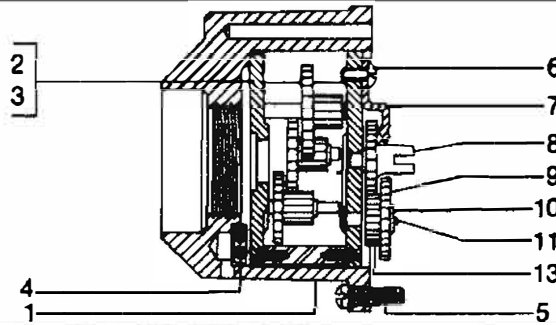
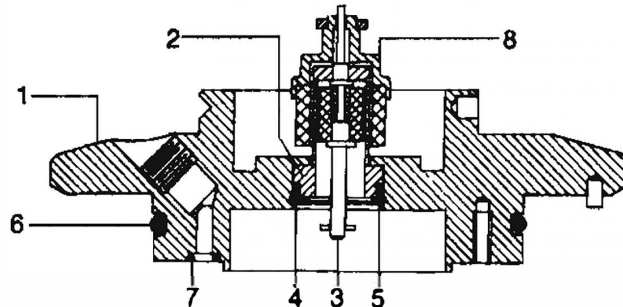

ILLUSTRATION NUMBER	QUANTITY REQUIRED	PART DESCRIPTION	PART NUMBER
1	1	Mechanism Housing Assembly	006-20-208-01
		Basic Gear Training Assembly Includes Illustration Numbers 10, 11 Cubic Foot Output Metric Output	006-20-212-00 006-20-212-01
3	1	Complete Internal Gear Train Assembly, Includes Illustration Numbers 2, 6 thru 10, 12 thru 14 Cubic Foot Output Metric Output	006-20-412-00 006-20-412-01
*4	1	Filter Screen, Stainless Steel	006-16-083-21
5	5	#6-32 x 1/2" Long Fillister Head Stainless Steel Machine Screw	903360
6	1	#4-40 x 3/16" Long Rd. Hd. Br. Machine Screw	903023
7	1	Gear Retainer	006-20-080-00
8	1	40 Tooth Coupling Gear	006-20-440-40
9	1	Large Change Gear (NOTE: "YY" Refers to the Number of Gear Teeth. Digits Must Be Substituted for "YY" When Ordering.)	006-20-445-"YY"***
10	1	Retaining Ring, Stainless Steel	907159
11	1	6th Change Gear Shaft	006-20-361-01
12	1	Small Change Gear (See Note for Illustration Number 9 Above) (Not Shown)	006-20-226-"YY"***
13	1	26T Gear and Pin Assembly	006-20-326-26
14	1	#2-56 x 1/8" Long Hexagon Stainless Steel Set Screw, Nylock for Small Change Gear (Not Shown)	950218

\* Recommended Spare Parts

\*\* For 46/49 Change Gear, Order Part Number 006-20-446-49

\*\*\* For 25/27 Change Gear, Order Part Number 006-20-325-27



## Top Plate and Magnetic Coupling Assembly

ILLUSTRATION NUMBER	QUANTITY REQUIRED	PART DESCRIPTION	PART NUMBER
1a	1	Top Plate, w/o Tapping For High Speed Pulser	006-20-003-02
1b	1	Top Plate w/Tapping For High Speed Pulser	006-20-003-04
2	1	Driver Magnet Well and Post Assembly	006-20-244-00
3	1	Driver Magnet and Shaft Assembly	006-20-315-00
*4	1	O-Ring, #523 EU, Parker 2-113	950196
*4	1	O-Ring, Viton, Parker 2-113	904840
5	1	Tru-Arc Retaining Ring #5000-75 MD	904423
*6	1	O-Ring, #523 EU, Parker 2-232	950197
*6	1	O-Ring, Viton, Parker 2-232	950267
*7	1	O-Ring, #523 EU, Parker #2-5	904379
*7	1	O-Ring, Viton, Parker #2-5	906742
8	1	Follower Magnet and Holder Assembly	006-20-444-00

\*Recommended Spare Parts

## TPL-9 Turbo-Meters, 2" and 3"      2" and 3" TPL-9 Turbo-Meters, Change Gears

Cubic Foot Output Meters

ITEM	CHANGE GEAR AND BASIC BLANKS	RATIO	% OF CHANGE IN METER REGISTRATION
1.	45-43T/26-26T	1.65385	0.77
2.	45-45T/26-27T	1.66667	0.71
3.	45-47T/26-28T	1.67857	0.08
4.	45-42T/26-25T	1.68000	0.73
5.	45-44T/26-26T	1.69231	0.67
6.	45-46T/26-27T	1.70370	0.62
7.	45-48T/26-28T	1.71428	0.33
8.	45-43T/26-25T	1.72000	0.62
9.	45-45T/26-26T	1.73077	

Base = 44T/26T

Cubic Foot Output Meters

ITEM	CHANGE GEAR AND BASIC BLANKS	RATIO	% OF CHANGE IN METER REGISTRATION
1.	45-44T/26-25T	1.76000	0.52
2.	45-46T/26-26T	1.76923	0.48
3.	45-48T/26-27T	1.77778	0.78
4.	45-43T/26-24T	1.79166	0.46
5.	45-45T/26-25T	1.80000	0.43
6.	45-47T/26-26T	1.80769	0.39
7.	46-49T/25-27T	1.81481	1.02
8.	45-44T/26-24T	1.83333	0.36
9.	45-46T/26-25T	1.84000	

Base = 45T/25T

### Readout Mounting

When a TPL-9 Turbo-Meter is ordered with a horizontal direct reading index, the assembly shown at the left will be mounted on the meter. ALL other readout devices, including integrating or recording gauges, require mounting of index plate assembly 006-20-504-02 on the face plate of the intermediate gear housing. This index plate is pre-drilled to accept mechanical indexes, integrating or recording gauges. Additionally, for horizontal sets, the index plate will accept the 90° goose-neck shown below to position the gauge properly.

The 90° goose-neck adapter for TPL-9 Turbo-Meters of any working pressure is:  
Part Number 006-22-407-00.

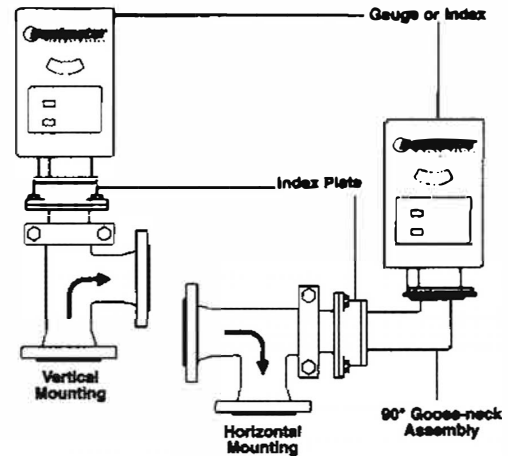

### TPL-9 Turbo-Meters, 2" and 3" Safety Interlock Device

#### Complete Retrofit Kit

PART DESCRIPTION	PART NUMBER
For 2" TPL-9	006-16-677-01000
For 3" TPL-9	006-20-677-00000

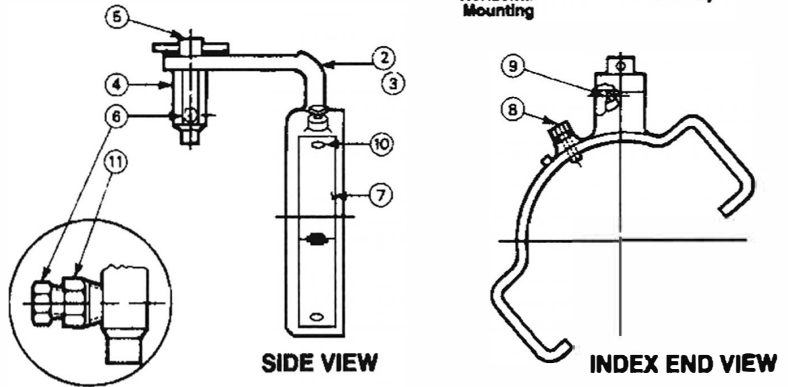

ILLUSTRATION NUMBER	QUANTITY REQUIRED	PART DESCRIPTION	PART NUMBER
2	1	2" TPL-9 Half-Clamp Cover Assembly	006-16-177-00
3	1	3" TP-9 and 3" TPL-9 Half-Clamp Cover Assembly	006-20-177-00
4	1	Relief Valve, 3" TP-9, 2" and 3" TPL-9	006-20-142-00
5	1	Relief Valve Stem	006-20-144-01
6	1	1/4"-18 NPT Hexagon Head Pipe Plug	950179
7	1	Danger Label	006-20-136-03
8	1	5/16"-18 NC x 1-1/4" Long Hexagon Head Machine Screw	950592
*9	1	Roll Pin .094 Diameter x 7/8" Long	950531
10	2	#4-3/16" Long Drive Screw	903504
11	1	1/8" Male to 1/4" Female NPT Connection	950553
12	1	2cc Container Loctite, 277 Red	1191465

\*Recommended Spare Parts



805 Liberty Boulevard  
DuBois, PA 15801  
1-800-METER=IT

---

## Authorized Distributor

All products purchased and services performed are subject to Sensus' terms of sale, available at either; <http://na.sensus.com/TC/TermsConditions.pdf> or 1-800-METER-IT. Sensus reserves the right to modify these terms and conditions in its own discretion without notice to the customer.

This document is for informational purposes only, and SENSUS MAKES NO EXPRESS WARRANTIES IN THIS DOCUMENT. FURTHERMORE, THERE ARE NO IMPLIED WARRANTIES, INCLUDING WITHOUT LIMITATION, WARRANTIES AS TO FITNESS FOR A PARTICULAR PURPOSE AND MERCHANTABILITY. ANY USE OF THE PRODUCTS THAT IS NOT SPECIFICALLY PERMITTED HEREIN IS PROHIBITED.